

# ISO/TC163/SC2報告と新WG17 について

2023年3月15日

日本板硝子株式会社

木下 泰斗

1

## ISO/TC163/SC2

Thermal performance and energy use in the built environment – Calculation methods

Chair: Lars MYHRE (~2022)

Arnkell Jonas PETERSEN (2023~)

- **WG4**
  - Industrial calculations
- **WG15**
  - Energy Performance calculation methods
- **WG16**
  - Hourly data for assessing the annual energy use for heating and cooling
- **WG17**
  - Thermal performance of windows, doors and shading devices — Detailed calculations

2

# WG4

## Industrial calculations

- Convenor: 鉾井先生
- **ISO 12241:2022** (建築設備及び産業用装置のための断熱－計算法)  
“Thermal insulation for building equipment and industrial installations — Calculation rules”
- 2022年3~4月 FDIS投票
- 2022年6月発行

4

# WG15

## Energy Performance calculation methods

- Convenor: Dick van DIJK (NL)
- **ISO 52016-1:2017** (熱負荷計算手順)  
“Energy performance of buildings — Energy needs for heating and cooling, internal temperatures and sensible and latent heat loads — Part 1: Calculation procedures”
- **ISO/DIS 52016-3** (適応性外皮部位の計算手順)  
“Part 3: Calculation procedures regarding adaptive building envelope elements”  
－ 近々FDIS投票へ
- **ISO/TR WD 52016-4** (Part 3の技術情報)  
“Part 4: Explanation and justification of ISO 52016-3”
- **ISO/WD 52016-5** (熱負荷計算の妥当性確認)  
“Part 5: Specific criteria and validation procedures”

5

# WG16

## Hourly data for assessing the annual energy use for heating and cooling

- Convenor: Jean-Marie ALESSANDRINI (FR)
- **ISO/PWI 15927-4** (時刻別気象データ)

“Hygrothermal performance of buildings — Calculation and presentation of climatic data — Part 4: Hourly data for assessing the annual energy use for heating and cooling”

– 熱負荷計算用将来気象データの統計的取り扱い構築中，3年追加でPWI継続

6

# WG17

## Thermal performance of windows, doors and shading devices — Detailed calculations

- Convenor: Robert MARSHALL (CA)
- **ISO/PWI 15099** (窓の熱性能計算法)

“Thermal performance of windows, doors and shading devices — Detailed calculations”

7

# WG17新設経緯

2021/3~2021/6	NP 7538投票 (CA提案) "Clear Energy Generating PV Building Envelope Components"	否決 ISO/TC160 & IEC/TC82と重複の可能性指摘
2021/4~2021/9	ISO 15099 SR投票	Confirm 6/11, Revise 5/11, CA, UK, CNのみExpert登録
2021/8/23	Letter from CA 「ISO 15099 SRでClear Active BIPV追加に協力を！」	
2021/10/26	SC2 web会議 CAからISO 15099改正提案プレゼン	ISO/TC160とのリエゾン代表募集を決議
2022/3~2022/6	NP 15099投票 Clear Window BIPV追加	PWI登録承認 UK, DE, BE, CHが反対
2022/6~2022/8	WG17新設のDraft Resolution投票	承認 BE, CHのみ反対
2022/9/21	SC2 web会議	Robert MARSHALLをISO/TC160とのリエゾン代表に選出を決議
2022/11/15	WG17 1st meeting	CD登録上申を決議
2023/2~2023/4	CD登録投票	投票中

8

## NP 15099 (CA提案)

- 目的：Clear Window BIPVの熱性能計算法 (g-value) を追加
- 根拠：PV増加により，雇用安定，経済的利益，CO2排出削減，電力ピーク負荷削減など
- Project Leader: Robert MARSHALL (CA)
- WD段階から3年間
- SR投票時の各国コメントを考慮
- ISO/TC160 & IEC/TC82の作業との重複を避けるためリエゾン参加

9

# NP 15099 (CA提案)

The arrangement of 3 solar PV modules in clear window BIPV is shown in attached Figure X and Figure Y.

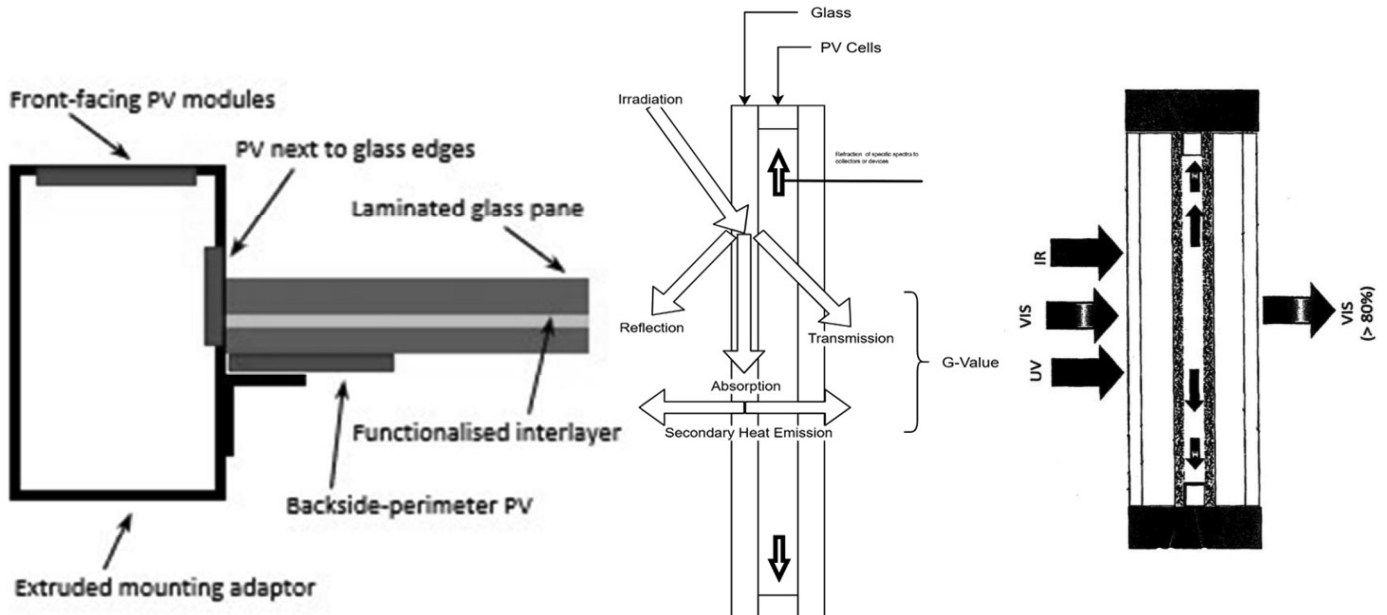

## NP 15099に対する欧州意見

<p>(Belgium)</p> <p>The proposed revision is very limited and is not justified. The justification of the proposal seems to cover all types of BIPV, including these already covered by the JWG between IEC/TC82 and ISO/TC160. But surprisingly, the annexes to form 4 (draft + drawing) show a system that is extremely marginal in photovoltaic applications. There is no interest to amend ISO 15099 for such system, which has no impact on the U-value anyway. Revision of ISO 15099 should better wait until the revision of ISO 9050 is completed in order to align both standards. ISO/TC163/SC2 has been invited to join the JWG mentioned above.</p> <p>The BIPV system shown in the draft is not usual. The most usual BIPV systems have cells embedded in the laminated glass. Those should be treated first, as their use is much more expanded. The standard ISO 9050 would be more suitable to contain this kind of assembly.</p>	<p>(UK)</p> <p>The Joint Working Group JWG 11 of ISO/TC160/SC1/WG9 and IEC/TC82 is currently addressing two proposals for determining the g value (Solar Heat Gain Coefficient) of BIPV, taking into account the proportion of the absorbed solar energy that is removed as electricity. Members of that JWG who are also participating in the revision of EN 50583 (the European BIPV standard) proposed that the presentation on the 'calculation-based method' be considered as a basis for addressing this matter within EN 410 (by CEN/TC129/WG9) and ISO 9050 (by ISO/TC160/SC2/WG2). If ISO/TC163 also develops a calculation for determining the g value (and SHGC) of BIPV, then there is real danger that we end up with two different methodologies, which the glass and glazing sector does not want.</p>
<p>(Switzerland)</p> <p>This is a snapshot initiated by some manufacturer promoting a specific solution (with rather small impact). In order to include BIPV comprehensively in this standard, more technologies should be considered, such as partial shading with PV etc. A technology survey would probably make sense before launching this revision.</p>	<p>(Germany)</p> <p>The current calculation methods of EN ISO 10077-2:2017 and ISO 15099:2003 have been implemented in the new calculation software for calculating heat flows, thermal bridges, isotherms and Uf values. Therefore, there is no need to change the current ISO 15099.</p>

# WG17 1<sup>st</sup> meeting

- 日時：2022/11/15 23:00~25:00 (Zoom会議)
- 参加者：5か国 9名 (CA, CN, AT, IT, JP)
- ISO 15099改正の背景
  - ISO 52016-3ではBIPVが除外された
  - BIPV熱性能規格のNP投票実施
  - ISO/TC160 & IEC/TC82と調整し、重複を避けるため、ISO/TC163ではClear Window BIPVをISO15099改正に導入
- 改正案の説明と議論
  - 屋根と壁のBIPVや不透明日射遮蔽物BIPVは適用範囲外？ (中国)
  - ドアに施工されるBIPVあるのか？ (中国)
  - ガラスエッジやフレーム上にPVセル配置したBIPVの採用例は多いのか？ (日本)
  - ガラス面で発電するBIPVを扱うべき。(日本)
- 決議案：CD段階へ進めることをSC2へ要請
- 次回：2023/2予定

15

## ISO/TC160 & IEC/TC82動向

- ISO/TC160 & IEC/TC82
  - IEC 63092-3作成中 “Photovoltaics in buildings – Part 3: Evaluation methodology of SHGC for building Integrated photovoltaic modules with various designs”
  - ISO 19467 (人工光源によるg値測定) と ISO 9050 (分光測定からg値計算) から任意セル面積率でのBIPVのg値を算出

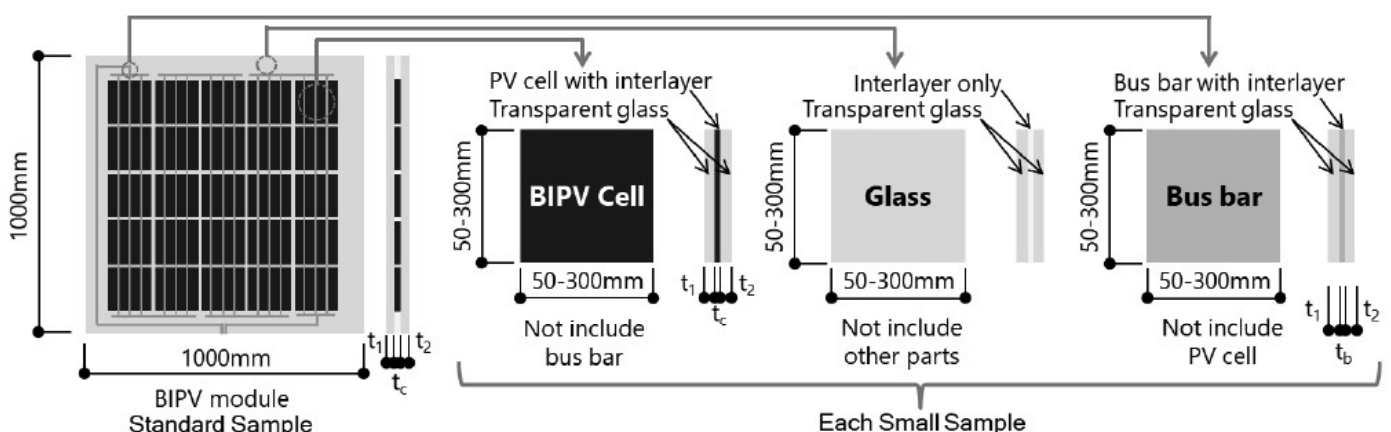

# CEN/TC129 & ISO/TC160動向

- CEN/TC129 & ISO/TC160
  - EN 410改正中 “Glass in building – Determination of luminous and solar characteristics of glazing”
  - ISO 9050改正中 “Glass in building – Determination of light transmittance, solar direct transmittance, total solar energy transmittance, ultraviolet transmittance and related glazing factors”
  - BIPVガラスの日射吸収率から発電効率を差し引いてg値計算

$$\alpha_e = q_i + q_e + \eta$$

$$g = \tau_e + q_i = \tau_e + (\alpha_e - \eta) \frac{h_i}{h_e + h_i}$$

$\alpha_e$  : ガラスの日射吸収率  
 $q_i$  : 室内側への放熱率  
 $q_e$  : 室外側への放熱率  
 $\eta$  : PVの発電変換効率  
 $g$  : 日射熱取得率  
 $\tau_e$  : 日射透過率  
 $h_i$  : 室内側熱伝達係数  
 $h_e$  : 室外側熱伝達係数

17

## 今後の予定

- ISO 15099改正スケジュール
  - 2023/2 CD登録
  - 2024/12 DIS登録
  - 2025/7 FDIS登録
  - 2026/1 ISO発行
- IEC 63092-3発行 202x年
- EN410 & ISO 9050改正 2025年以降？

19